

(No Model.)

2 Sheets—Sheet 1.

W. W. TUCKER.
MACHINE FOR MILLING PLUG VALVES.

No. 482,211.

Patented Sept. 6, 1892.

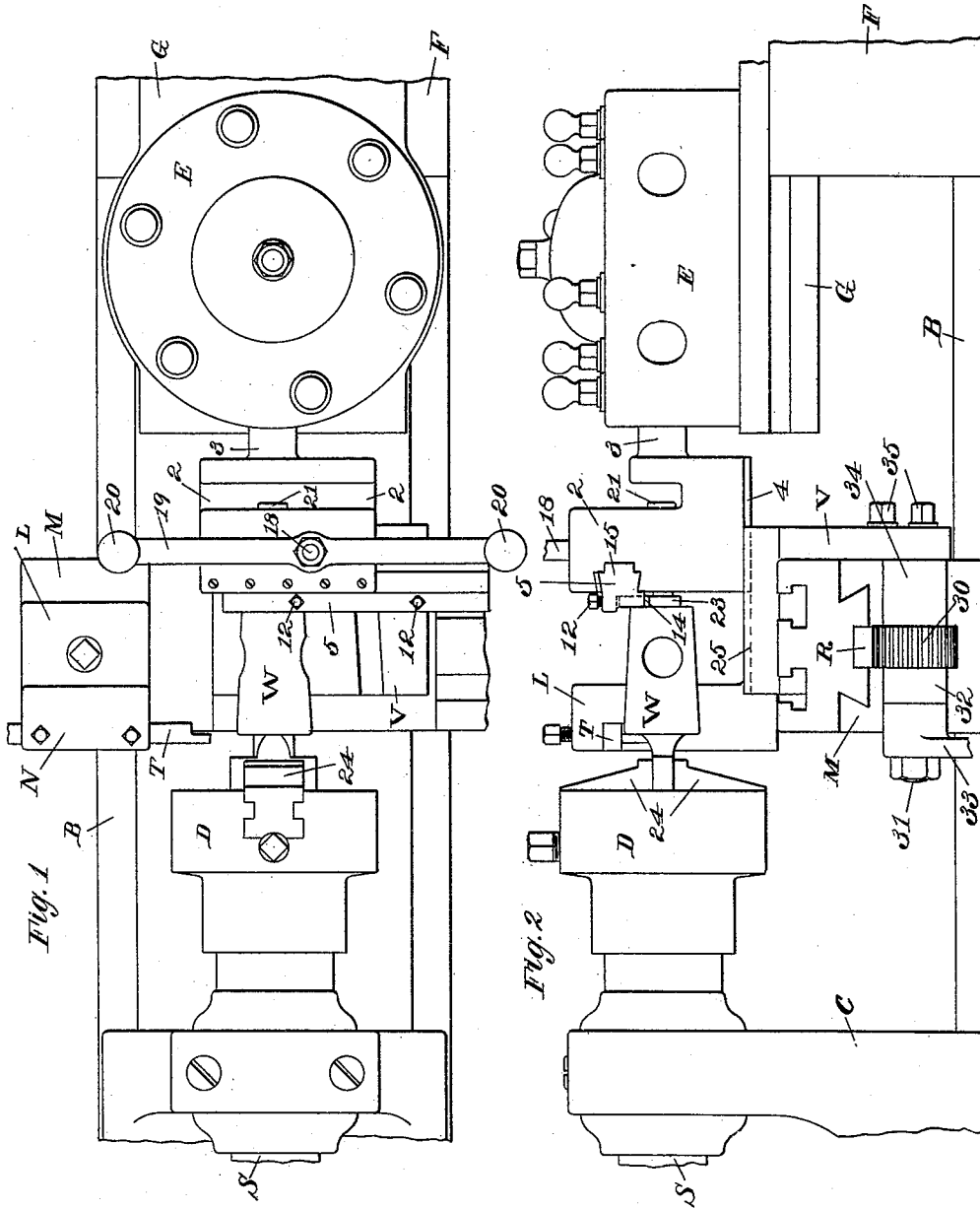

Fig. 1

Fig. 2

Witnesses:
H. Mallner.
Henry R. Reekard.

Inventor:
W. W. Tucker.
By his Attorney,
J. A. Richards.

W. W. TUCKER.
MACHINE FOR MILLING PLUG VALVES.

No. 482,211.

Patented Sept. 6, 1892.

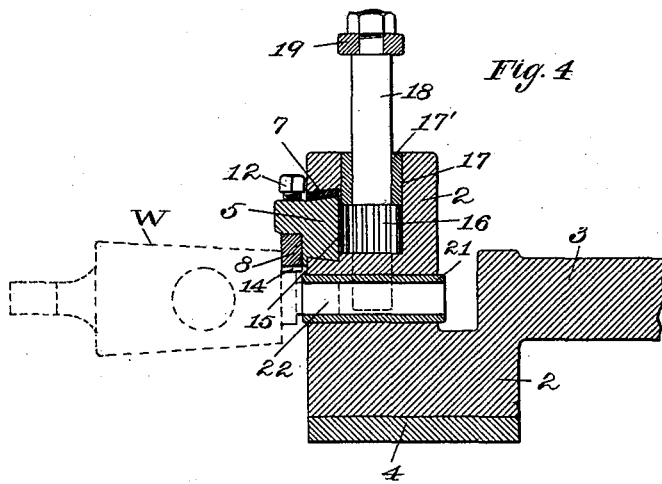
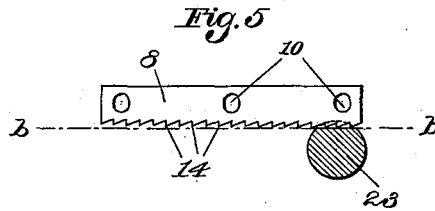
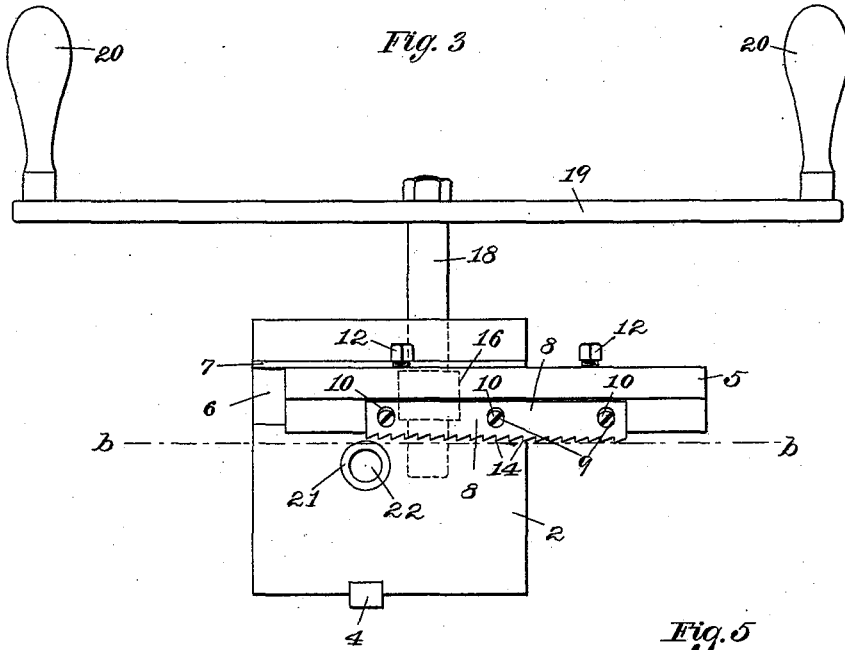

Inventor:

W. W. Tucker.

By his Attorney,

F. W. Richards

Witnesses:

H. Mallner

Henry L. Reckard.

UNITED STATES PATENT OFFICE.

WILLIAM W. TUCKER, OF HARTFORD, CONNECTICUT.

MACHINE FOR MILLING PLUG-VALVES.

SPECIFICATION forming part of Letters Patent No. 482,211, dated September 6, 1892.

Application filed July 13, 1891. Serial No. 399,433. (No model.)

To all whom it may concern:

Be it known that I, WILLIAM W. TUCKER, a citizen of the United States, residing at Hartford, in the county of Hartford and State of Connecticut, have invented certain new and useful Improvements in Milling-Tools, of which the following is a specification.

This invention relates to milling-tools adapted to be used on turret-lathes for milling or flattening the plugs of plug-cocks and of other like articles.

In the drawings accompanying and forming a part of this specification, Figure 1 is a plan view of a portion of an ordinary turret-lathe provided with a milling-tool embodying my invention. Fig. 2 is a front elevation of the parts shown in Fig. 1. Fig. 3 is an end elevation, on an enlarged scale, of the milling-tool as seen from the left hand in Figs. 1 and 2. Fig. 4 is a vertical longitudinal section of the tool. Fig. 5 is a diagrammatic view illustrating the operation of the cutter and showing the position thereof at the completion of the cut.

Similar characters designate like parts in all the figures.

The turret-lathe partially shown in the drawings comprises the usual bed or frame B, head-block C, turret-slide block F, turret-slide G, turret E, lathe-spindle S, and a suitable chuck, as D, on said spindle. The lathe is also usually furnished with the "cut-off slide" L, which is fitted to slide in the cut-off block M and carries the cut-off-tool holder N for holding the cut-off tool T. This slide may be actuated by hand in the usual manner by means of the rack R, fixed to the under side thereof, the gear 30 meshing with said rack and carried by a shaft 31, mounted in bearings, as 32 and 34, on said block M, said shaft and gear being rotated by some suitable lever, as 33, Fig. 2. The turret E is of the well-known construction and is arranged to be intermittently revolved and locked on the slide G by means of the usual turret-actuating and turret-locking apparatus. (Not herein shown.)

The tool has a suitable stock (designated in a general way by 2) and having a stem or shank 3, which is securely clamped in the turret E in the usual manner. A tongue or key 4, fixed in or to the under side of the fixture or stock 2, is fitted to move longitudi-

nally in a guide-slot 25, formed in the guide-bracket V, which bracket is removably fixed by means of screws 35 to one side of the afore-said cut-off block M.

A cutter-slide (designated by 5) is fitted to slide crosswise of the axes of the tool in a groove 6, Fig. 3, which is formed in the fixture 2, and is provided with a gib 7 for taking up the wear of said slide. The slide 5 has adjustably fixed thereto the cutter 8 by means of suitable clamping-screws, as 9, which screws pass through elongated slots 10, formed in said cutter. Set-screws, as 12, are provided for adjusting the cutter toward the work. Suitable cutting-teeth 14 are formed in the lower edge of the cutter, and, as shown in the drawings, each tooth from the left toward the right projects slightly below the next preceding tooth after the manner of the ordinary "broach." This is shown in Fig. 3 by contrast with the dotted line *b b*, which is parallel to the slide movement.

For the purpose of actuating the cutter-slide rack teeth 15 are formed on the rearward side thereof, which teeth mesh with the pinion 16, which is fitted in a bore at 17 in the fixture 2. Said pinion is carried on a shaft 18, which is journaled in the said fixture substantially as shown and is provided with a handle bar or lever 19, furnished with suitable handles, as 20 20, by means of which the operator may rotate the pinion for advancing or retracting the cutter. A removable bushing 17', Fig. 4, serves to hold the shaft in place, said bushing being fixed in the stock 2 by means of a set-screw or like device. (Not shown.)

A removable guide-bushing, as 21, is fitted into the fixture 2 and has a bore 22 of a size to receive one end of the article to be milled, which is thereby properly located and firmly supported during the milling operation. One of these bushings is to be furnished for each different size of piece to be milled.

For the purpose of illustrating the general operation of my improved milling-tool I have shown in Figs. 1 and 2 of the drawings an ordinary valve-plug W, on the shoulder 23 of which it is desired to mill a flat spot, as illustrated in the sectional view, Fig. 5. As shown, the piece W is held in place by the chuck D, being securely clamped between the jaws 24

thereof. The operator next moves forward the turret and the milling-tool carried thereby until the tongue 4 of said tool enters the guide-slot 25 of the guide-bracket V and the stem or reduced part 23 of the piece W enters the bore 22 of the guide-bushing 21. At this time the turret-slide G should be clamped by the slide-clamp usually provided for that purpose, so that the turret may not be retracted by the cutter during the milling operation. When the tool has thus been brought to the desired position, the slide 5 being forward, as in Figs. 1 and 3, the operator by means of the handle-bar and the connections above described advances the cutter from its position in Fig. 3 to that shown in Fig. 5, thereby making a series of cuts on the shoulder 23 and leaving the same flattened off or squared, as shown in section in said Fig. 5.

My improved milling or plug-squaring device is especially designed for use in the making of plugs for water, gas, and steam valves, which plugs have a tenon or short portion 23, flattened on one side, as shown, for preventing the usual washer from turning thereon.

Having thus described my invention, I claim—

1. The combination, with a suitable holder or stock having a guide for the piece to be

milled, of the cutter-slide fitted to move cross-wise of said guide at one side thereof, a cutter fixed on said slide slightly inclined to the line of movement thereof, and means actuating the slide, substantially as set forth.

2. The combination, with a holder or stock substantially as described, of the removable guide-bushing, the cutter-slide, the cutter set inclined on said slide, means for adjusting the cutter on the cutter-slide, a shaft geared to the cutter-slide and journaled in said holder, and means for revolving the shaft by hand, substantially as set forth.

3. The combination, with the spindle-chuck and turret of a turret-lathe, of the guide-bracket having the guide-slot therein, the milling-tool holder fixed in the turret and having the guide constructed to enter and slide in said guide-slot and constructed, substantially as described, to support the piece to be milled, a sliding cutter carried by said holder, and means for actuating said cutter in a direction crosswise to said guide-slot, all substantially as set forth.

WILLIAM W. TUCKER.

Witnesses:

FRANCIS H. RICHARDS,
HENRY L. RECKARD.